



Applies To: **See VEHICLES AFFECTED**

**September 24, 2002**

## Safety Recall: Ignition Switch (Supersedes 02-031, dated September 17, 2002)

### BACKGROUND

Electrical contacts in the ignition switch can wear prematurely due to high electrical current passing through the switch. Worn out ignition contacts could cause the engine to stall without warning. Although the engine will restart in most cases, a vehicle that stalls while driving increases the risk of a crash.

### VEHICLES AFFECTED

- 1997 Accord (L4)
- 1998–99 Accord (L4 and V6)
- 1998–00 Civic
- 1997–99 CR-V
- 1997–00 Odyssey
- 1997–99 Prelude

**Not every vehicle in the years and models listed above is affected by this campaign.** Before beginning work, verify that the vehicle is eligible by checking at least one of the following.

- The customer has a notification letter.
- The vehicle is shown on your campaign responsibility report.
- The vehicle is shown as eligible on a DCS or iN (Interactive Network) VIN Status Inquiry.

### CUSTOMER NOTIFICATION

All owners of affected vehicles will be sent a notification of this campaign. An example of the customer notification is at the end of this service bulletin.

### CORRECTIVE ACTION

Replace the electrical (ignition) switch.

**NOTE:** *Reinstalling aftermarket parts (security systems, alarms, audio systems, etc.) connected to the ignition wiring is not covered under this campaign.* If a customer wants a non-Honda part reinstalled, the shop that installed the part (or the customer) must do the work and assume liability. In addition, the customer is responsible for all costs associated with the non-Honda part and its installation. If you have any questions about this, please contact your District Service Manager.

### PARTS INFORMATION

Ignition Switch:

1997 Accord – (L4)	P/N 35130-SY8-305 H/C 7205255
1998–99 Accord – (L4 and V6)	P/N 35130-S84-305 H/C 7204415
1998–00 Civic –	P/N 35130-S04-305 H/C 7205297
1997–99 CR-V –	P/N 35130-S10-306 H/C 7205305
1997 Odyssey –	P/N 35130-SX0-406 H/C 7205263
1998 Odyssey –	P/N 35130-SX0-305 H/C 7205271
1999–00 Odyssey –	P/N 35130-S0X-305 H/C 7204423
1997–99 Prelude –	P/N 35130-S30-305 H/C 7205289

### TOOL INFORMATION

Terminal Pin Tool: P/N 07JAZ-002020A, H/C 3087749  
(part of Terminal Pin Tool Set,  
P/N 07JAZ-002000A, H/C 3087715)

### WARRANTY CLAIM INFORMATION

Description	FRT	Template ID
Replace ignition switch		
1997 Accord (L4)	0.5	02-031A
1998–99 Accord (L4 and V6)	0.4	02-031B
1998–00 Civic	0.6	02-031C
1997–99 CR-V	0.4	02-031D
1997 Odyssey	0.4	02-031E
1998 Odyssey	0.4	02-031F
1999–00 Odyssey	0.7	02-031G
1997–99 Prelude	0.5	02-031H

Operation Number: 725108

Failed Part: P/N 35130-S84-A01  
H/C 5435458

Defect Code: 5B0 (the "0" is a zero)

Contention Code: L55

Skill Level: Repair Technician



## REPAIR PROCEDURE

- Use **Procedure A** on 1997 Accords (L4).
- Use **Procedure B** on 1998–99 Accords (L4 and V6).
- Use **Procedure C** on 1998–00 Civics.
- Use **Procedure D** on 1997–99 CR-Vs.
- Use **Procedure E** on 1997–98 Odysseys.
- Use **Procedure F** on 1999–00 Odysseys.
- Use **Procedure G** on 1997–99 Preludes.

### Procedure A: 1997 Accords (L4)

1. Remove the dashboard lower cover, the knee bolster, and the steering column covers (see the 1997 Accord Service Manual, page 23-75, steps 2 and 3).
2. Disconnect the 7P and 8P connectors from the ignition switch body.

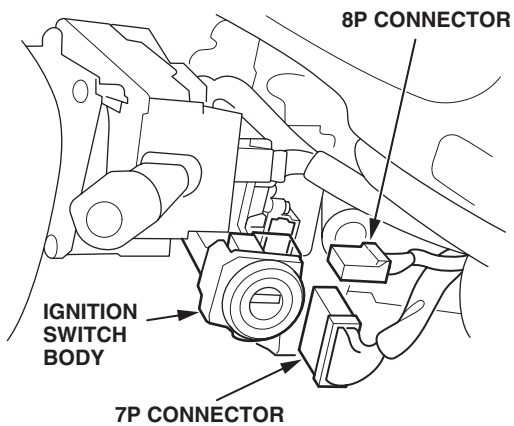

3. Remove the steering column holder mounting bolts and nuts. Lower the steering column.

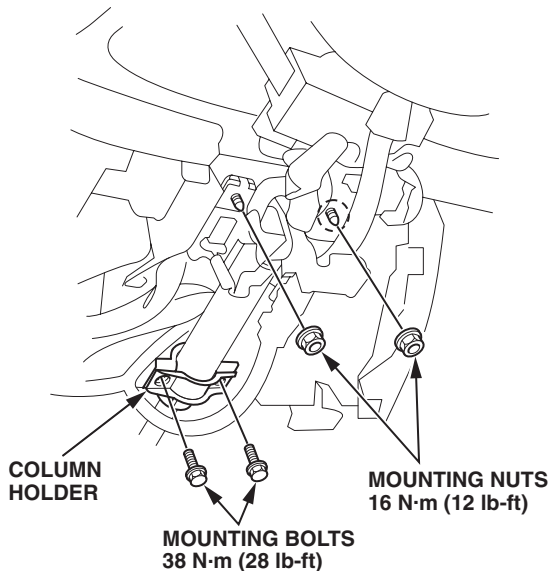

4. Center-punch both shear bolts on the ignition switch body, and drill off each bolt head with a 5 mm (3/16 in.) drill bit. Be careful not to damage the switch body.

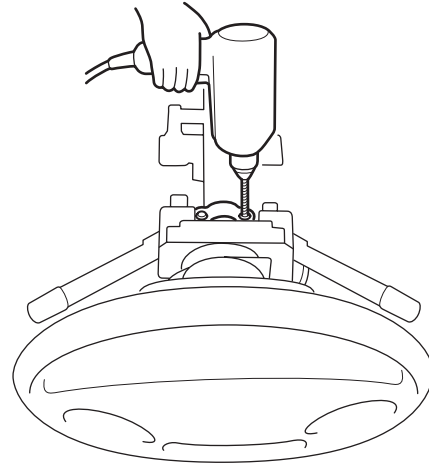

5. Remove the shear bolts from the ignition switch body, and discard them. Then separate the switch body from the steering column.
6. Remove the screws from the electrical switch, then remove the electrical switch from the ignition switch body. Discard the electrical switch.

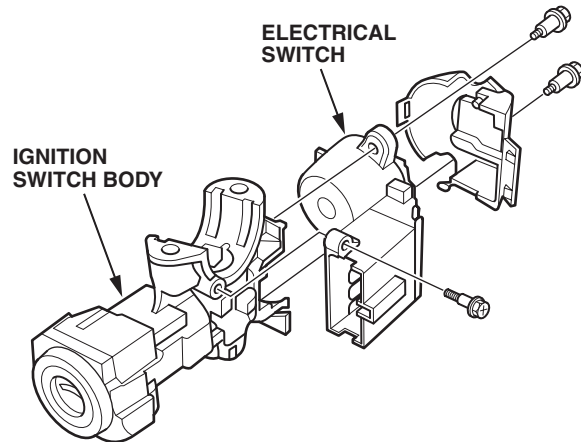

7. Install the new electrical switch with the original screws.
8. Hold the ignition switch body up to the steering column, and loosely install the new shear bolts.
9. Insert the key in the ignition switch. Make sure the key turns freely, and the steering column lock works correctly.
10. Tighten the shear bolts until their hex heads twist off.

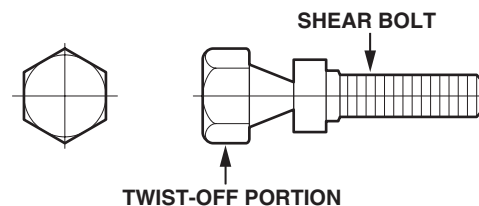

11. Raise the steering column, and install it with its mounting bolts and nuts. Torque the bolts to 38 N·m (28 lb-ft) and the nuts to 16 N·m (12 lb-ft).
12. Connect the 7P and 8P connectors.
13. Install the steering column covers, the knee bolster, and the dashboard lower cover.
14. Center-punch a completion mark above the eighth character of the engine compartment VIN.

Center-punch here.

**1HGCD5XXXHXXXXXX**

#### Procedure B: 1998–99 Accords (L4 and V6)

1. Remove the dashboard lower cover (see page 20-84 of the 1998–02 Accord Service Manual).
2. Disconnect the ignition switch harness 6P connector from the driver's under-dash fuse/relay box.

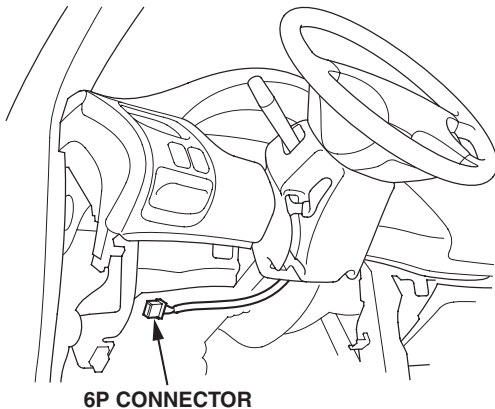

3. Remove the steering column covers (see step 4 on page 17-25 of the service manual).
4. Note how the ignition (electrical) switch harness routes to the fuse box; you'll need to route the new switch harness the same way.
5. Make sure the ignition switch is turned to LOCK (0).
6. Remove the screw from the side of the electrical switch cover.

**ELECTRICAL SWITCH**

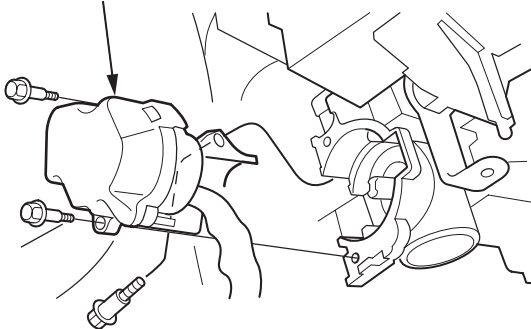

7. Remove the screws from the electrical switch, then remove and discard the switch and its harness.
8. Install the new electrical switch with the original screws and cover. Route its harness to the fuse box the same way the discarded harness was routed.
9. Connect the 6P connector.
10. Install the steering column covers and the dashboard lower cover.
11. Center-punch a completion mark above the eighth character of the engine compartment VIN.

Center-punch here.

**1HGC55XXXHXXXXXX**

#### Procedure C: 1998–00 Civics

1. Remove the driver's dashboard lower cover and the knee bolster (see page 20-68 of the 1996–00 Civic Service Manual).
2. Disconnect the ignition switch harness 5P connector from the under-dash fuse/relay box and the 7P connector from the main wire harness.

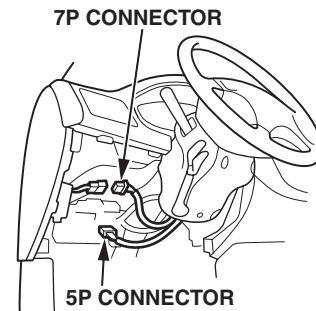

3. Remove the steering column covers (see page 17-37 of the service manual).
4. Note how the ignition (electrical) switch harness routes to the fuse box and main harness; you'll need to route the new switch harness the same way.
5. Remove and discard the wire tie clips from the 7P connector main wire harness. (Part of the harness will be reused.)

6. Remove the secondary lock from the 7P connector.

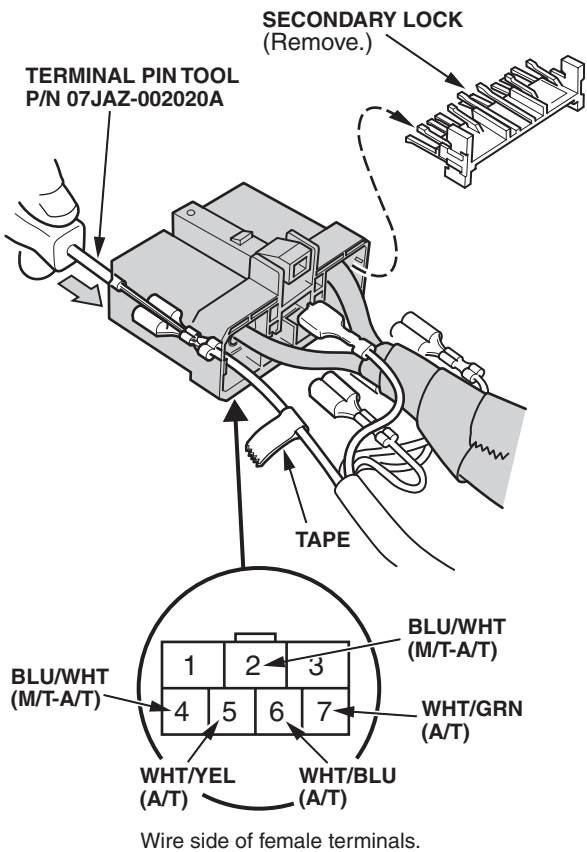

7. Remove terminals 2 and 4 (M/T vehicles) or terminals 2, 4, 5, 6, and 7 (A/T vehicles) from the 7P connector using the Terminal Pin Tool (P/N 07JAZ-002020A).

NOTE: Terminals 2 and 4 have BLU/WHT wires. To avoid mixing them up, label terminal 4 with a small piece of tape.

8. Make sure the ignition switch is turned to LOCK (0).  
9. Remove the screws from the electrical switch, then remove and discard the switch and its harness.

ELECTRICAL SWITCH

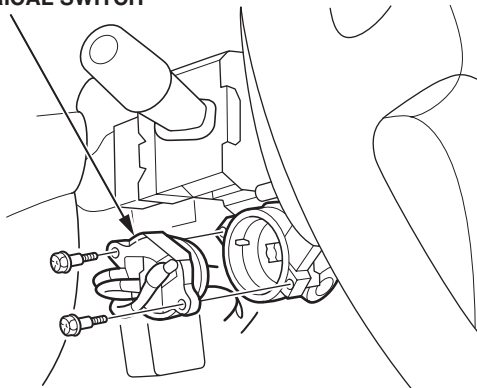

10. Install the new electrical switch with the original screws.

11. Remove the secondary lock from the 7P connector of the new main harness.

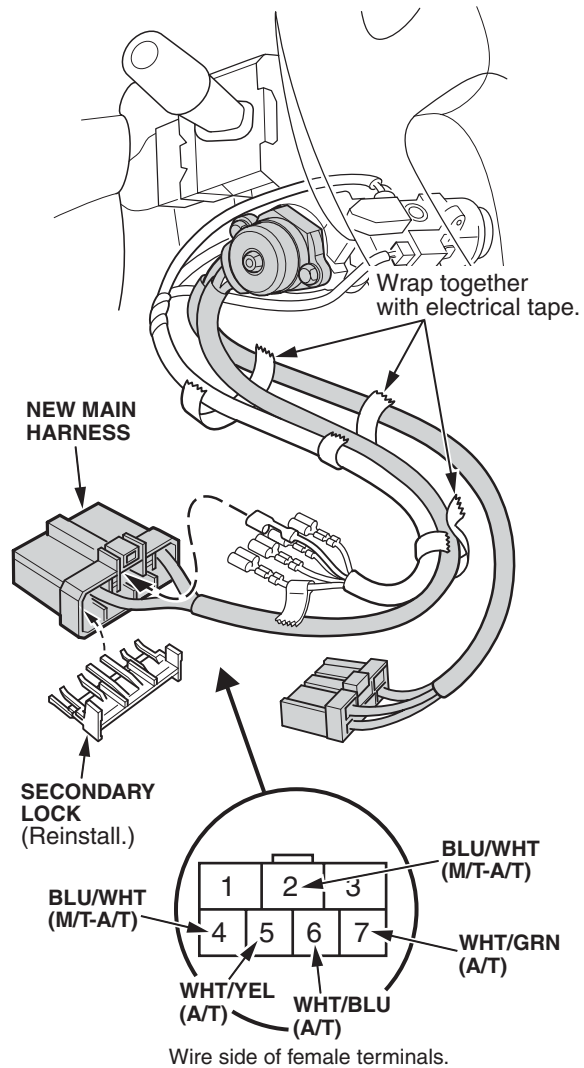

12. Install the terminals you removed from the original 7P connector into the new 7P connector.

13. Wrap both parts of the 7P main harness together with electrical tape.

14. Attach the new wire tie clips to the main harness in the same position as the original ties.

15. Route and attach the ignition switch harness and main harness the same way the original harnesses were installed.

16. Connect the 5P and 7P connectors.

17. Install the steering column covers, the knee bolster, and the driver's dashboard lower cover.

18. Center-punch a completion mark above the eighth character of the engine compartment VIN.

Center-punch here.

2HG EJ6XXXXHXXXXXX

### Procedure D: 1997–99 CR-Vs

1. Remove the driver's dashboard lower cover and the knee bolster (see page 20-48 of the 1997–01 CR-V Service Manual).
2. Disconnect the ignition switch harness 5P connector from the under-dash fuse/relay box and the 3P connector from the main wire harness.

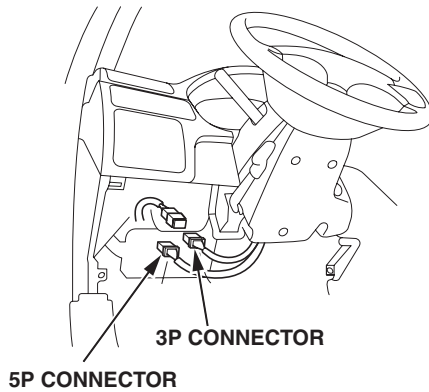

3. Remove the steering column covers (see page 17-20 of the service manual).
4. Note how the ignition (electrical) switch harness routes to the fuse box and main wire harness; you'll need to route the new switch harness the same way.
5. Make sure the ignition switch is turned to LOCK (0).
6. Remove the screws from the electrical switch, then remove and discard the switch and its harness.

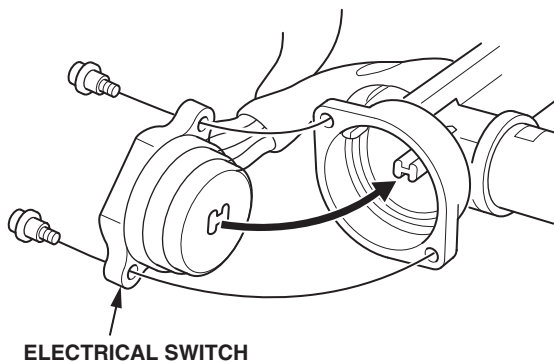

7. Install the new electrical switch with the original screws. Route its harness to the fuse box and main wire harness the same way the discarded harness was routed.
8. Connect the 5P and 3P connectors.
9. Install the steering column covers, the knee bolster, and the driver's dashboard lower cover.
10. Center-punch a completion mark above the eighth character of the engine compartment VIN.

Center-punch here.

JHLRD1XXXXHXXXXXX

### Procedure E: 1997–98 Odysseys

1. Remove the dashboard lower cover, the knee bolster, and the steering column covers (see page 23-65 of the 1998 Odyssey Service Manual).
2. Disconnect the ignition switch harness 7P connector from the under-dash fuse/relay box.

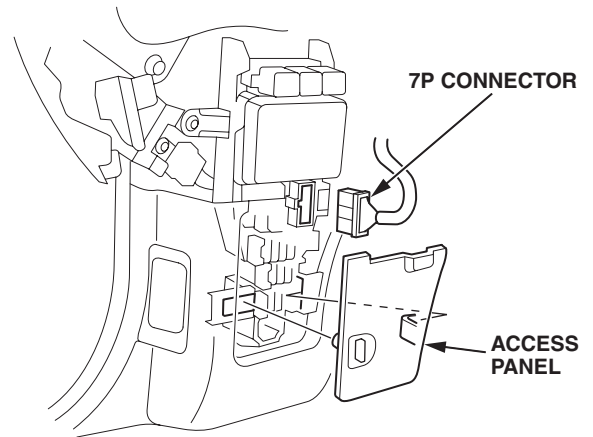

3. Note how the ignition (electrical) switch harness routes to the fuse box; you'll need to route the new switch harness the same way.
4. Make sure the ignition switch is turned to LOCK (0).
5. Remove the screws from the electrical switch, then remove and discard the switch and its harness.

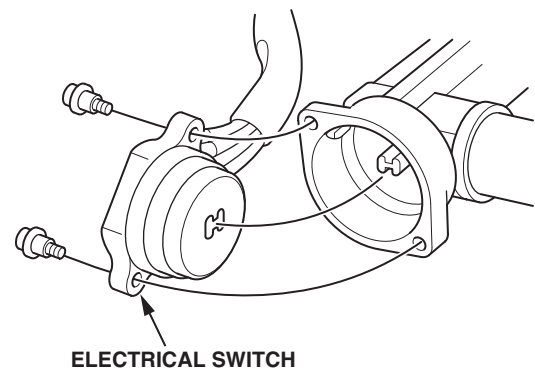

6. Install the new electrical switch with the original screws. Route its harness to the fuse box the same way the discarded harness was routed.
7. Connect the 7P connector.
8. Install the steering column covers, the knee bolster, and the dashboard lower cover.
9. Center-punch a completion mark above the eighth character of the engine compartment VIN.

Center-punch here.

JHMRA1XXXXHXXXXXX

## Procedure F: 1999–00 Odysseys

1. Remove the dashboard lower cover (see page 20-68 of the 1999–02 Odyssey Service Manual).
2. Remove the driver's door sill molding and the left kick panel (see page 20-57 of the service manual).
3. Remove the mounting nut and detach the clips from the driver's under-dash fuse/relay box. Pull the fuse box away from the body.

DRIVER'S UNDER-DASH FUSE/RELAY BOX

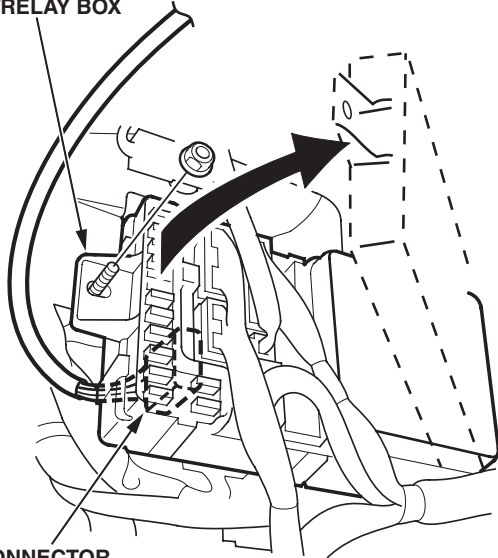

6P CONNECTOR  
(Located on the back of the fuse box.)

4. Disconnect the ignition switch harness 6P connector from the back of the fuse box.
5. Remove the steering column covers (see page 17-25 of the service manual).
6. Note how the ignition (electrical) switch harness routes to the fuse box, the main harness, and the ignition switch body; you'll need to route the new switch harness the same way.

7. Disconnect the ignition switch harness 4P connector from the main harness. Then disconnect its 5P connector from the ignition switch body.

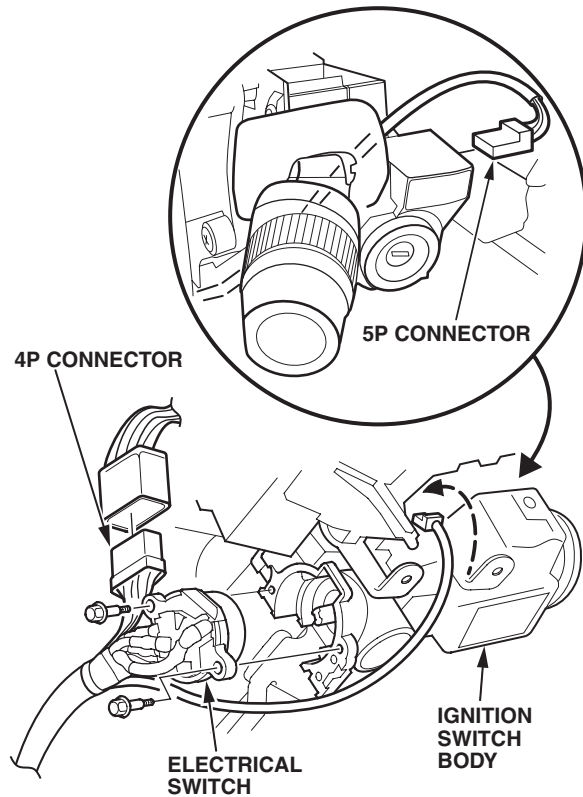

8. Make sure the ignition switch is turned to LOCK (0).
9. Remove the screws from the electrical switch, then remove and discard the switch and its harness.
10. Install the new electrical switch with the original screws. Route its harness to the fuse box the same way the discarded harness was routed.  
**NOTE:** To avoid harness damage, make sure you route the 5P connector portion of the harness exactly the same way the original was routed.
11. Connect the 5P connector to the ignition switch body, the 4P connector to the main harness, and the 6P connector to the fuse box.
12. Install the fuse box.
13. Install the door sill molding, the kick panel, the steering column covers, and the dashboard lower cover.
14. Center-punch a completion mark above the eighth character of the engine compartment VIN.

Center-punch here.

**2HKRL1XXXXHXXXXXX**

### Procedure G: 1997–99 Preludes

1. Remove the steering column covers (see page 17-21 of the 1997–99 Prelude Service Manual).
2. Make sure the ignition switch is turned to LOCK (0).
3. Disconnect the 7P connector from the ignition switch body.

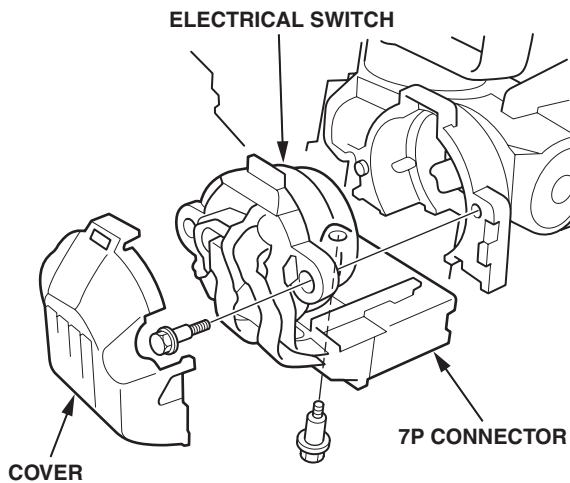

4. Remove the cover from the electrical switch, then remove the screws. Remove and discard the electrical switch and its harness.
5. Install the new electrical switch with the original screws and cover.
6. Connect the 7P connector.
7. Install the steering column covers.
8. Center-punch a completion mark above the eighth character of the engine compartment VIN.

Center-punch here.

**JHMBB6XXXXHXXXXXX**

#### Example of Customer Letter

Summer 2002

### Important Safety Recall: Ignition Switch

Dear Accord, Civic, CR-V, Odyssey, or Prelude Owner:

This notice is sent to you in accordance with the requirements of the National Traffic and Motor Vehicle Safety Act.

### What is the reason for this notice?

Honda Motor Co., Ltd., has determined that a defect relating to motor vehicle safety exists in the ignition switch on certain 1997 thru 2000 Honda automobiles. Electrical contacts in the ignition switch can wear prematurely due to high electrical current passing through the switch. Worn out ignition contacts could cause the engine to stall without warning. Although the engine will restart in most cases, if your engine stalls while driving in traffic or at highway speeds, you're at risk of being involved in a crash. Difficulties starting the engine (for example, hard-to-start, stalls immediately after starting, etc.) may indicate that the ignition switch is failing.

### What should you do?

Call any authorized Honda dealer, and make an appointment to have your vehicle repaired. The dealer will install an improved ignition switch, free of charge. Please plan to leave your vehicle at the dealership for half a day to allow the dealer flexibility in scheduling.

### Who to contact if you experience problems.

If you are not satisfied with the service you receive from your Honda dealer, you may write to

American Honda Motor Co., Inc.  
Automobile Customer Service  
Mail Stop 500-2N-7A  
1919 Torrance Blvd.  
Torrance, CA 90501-2746

If you believe that American Honda or the dealer has failed or is unable to remedy the defect in your vehicle, without charge, within a reasonable period of time (60 days from the date you first contact the dealer for a repair appointment), you may submit a complaint to

Administrator  
National Highway Traffic Safety Administration  
400 Seventh Street, SW  
Washington, DC 20590

Or call the toll-free Auto Safety Hotline at (888) 327-4236.

### What to do if you feel this notice is in error.

Our records show that you are the current owner or lessee of a Honda automobile involved in this recall. If this is not the case, or the name/address information is incorrect, please fill out and return the included, postage-paid *Information Change Card*. We will then update our records.

If you paid to have a defective ignition switch replaced sometime in the past, you may be eligible for reimbursement. Refer to the attached Instructions for Reimbursement for eligibility requirements and the reimbursement procedure.

### If you have questions.

If you have questions about this notice, or need assistance with contacting a Honda dealer, please call Automobile Customer Service at (800) 999-1009.

We apologize for any inconvenience this may cause you.

Sincerely,

**American Honda Motor Co., Inc.**  
**Honda Automobile Division**